

preeflow[®] Dosing system

by ViscoTec

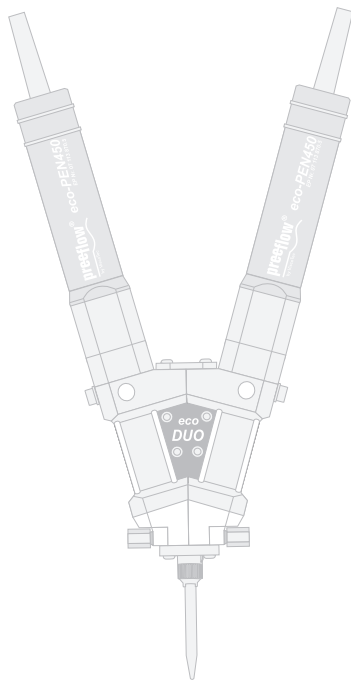

Operating and maintenance instructions

eco-CONTROL EC200 DUO

Contents

1	Introduction	5
2	Features	6
3	Scope of supply	7
	3.1 Mixer set - - - - -	7
4	Safety	8
	4.1 Informal safety measures - - - - -	8
	4.2 Use of symbols - - - - -	8
	4.3 Correct use, warranty - - - - -	8
	4.4 Qualifications of the operators and maintenance personnel - - - - -	9
	4.5 Organisational measures - - - - -	9
	4.6 Preparation for commissioning - visual inspection - - - - -	9
	4.7 Preventing material damage to the motors of the 2K-dispenser - - - - -	9
	4.8 Sources of danger due to Dosing system - - - - -	10
5	Operation	11
	5.1 Displays and controls - - - - -	11
	5.2 Connections - - - - -	12
	5.3 Symbols on the screen - - - - -	13
	5.4 Functional and operational schematic - - - - -	14
	5.5 Starting up for the first time - - - - -	15
	5.5.1 Save the calibration values of the dosing pressure sensors	15
	5.6 Starting up - - - - -	16
	5.6.1 Important settings	16
	5.7 Shutting down - - - - -	16
	5.8 The dosing programs and their areas of application - - - - -	16
	5.8.1 Dosing programs	17
	5.8.2 Operating modes	17
	5.9 Calibrating - - - - -	18
	5.9.1 Automatic calibration	18
	5.9.2 Calibration manual	19

5.10	Settings	- - - - -	20
5.10.1	Mixing ratio		20
5.10.2	Mixer size		20
5.10.3	Setting the pot life, flush the mixer		20
5.10.4	Dosing quantity		21
5.10.5	Dosing time		21
5.10.6	Flow rate		21
5.10.9	Dosing pressure monitor		22
5.10.7	Sucking back		22
5.10.8	Dosing time		22
5.10.10	Tolerance value primary pressure monitoring		23
5.10.11	Password protection		23
5.10.12	Analogue Input		26
5.10.14	System and error messages		27
5.10.13	Time and date		27
5.11	Creating dosing programs	- - - - -	28
5.12	Selecting the dosing program	- - - - -	28
5.13	Copying the dosing program	- - - - -	29
5.14	Changing a dosing program	- - - - -	30
5.15	Dosing, selected directly without dosing program	- - - - -	31
5.16	Dosing, using a dosing program	- - - - -	32
5.17	Monitoring / displaying dosing pressure	- - - - -	32
5.18	Manual flush	- - - - -	32
5.19	Bleeding the 2K-dispenser after filling / refilling it and after cleaning	- - - - -	33
5.20	Error messages	- - - - -	33
5.21	Clearing error messages	- - - - -	33
5.22	Error message dosing pressure monitor error	- - - - -	33
5.23	Service	- - - - -	34
5.23.1	Operating information		34
5.23.2	Formatting the memory card		34

6	Accessories / spare parts	34
----------	---------------------------	----

7	Troubleshooting / Maintenance	35
----------	-------------------------------	----

8	Technical data	36
----------	----------------	----

8.1	Dosing control	- - - - -	36
8.2	Dispenser	- - - - -	36
8.3	Interface description	- - - - -	37
8.3.1	System plugs		37
8.3.2	Logical links of the outputs		39

9	Disposal	43
----------	----------	----

10	EU Manufacturer's Declaration	43
-----------	-------------------------------	----

1 Introduction

Dear customer,

we congratulate you on buying your Dosing system. We are certain that it will fully meet your requirements. We wish you trouble-free and successful operation.

The dosing system eco-CONTROL EC200-K is made up of the dosing control and the 2K dispensers.

The Dosing system has been designed and tested for the most precise work with our dispensers. The Dosing system has a wide variety of setting options for the dosing quantity and time. All the values that are related to production can be saved and changed at any time. Operation is done via an intuitive operator guidance system using a graphic user interface. It is possible to operate two dispensers at the same time. It is possible to set it up for other dispensers at any time without noteworthy setting-up times.

The dispensers have been developed and tested for high-precision work with products ranging from low to high viscosity with extremely high repeat precision.

They are rotating displacement systems consisting of a rotor and stator and can be dismantled in no time. A number of voids are produced as a result of the various geometries of the conveying elements. Turning the rotor in the stator creates conveyance which is either proportional to the angle of rotation or rpm-dependent.

Since the direction of flow is reversible, the medium can be sucked back to allow a clean break of the thread. Self-sealing depends on the viscosity.

We would be glad of your help as part of our efforts to maintain our standard of quality at the highest possible level. Please tell us about any possible ways we can improve our product.

2 Features

Functions in brief with your transactions in the document:

Feature	Section	Page
3 dosing programs: Quantity Start/stop Time program	5.8.1	17
24 different dosing programs (operation with memory card)	5.11	28
Sucking back of the medium to prevent dripping	5.10.7	22
Adjustable pot life, automatic mixer filling	5.10.3	20
Adjustable flushflush time, prevents the medium from hardening in the mixer	5.10.3	20
Flow quantity per minute can be set	5.10.6	21
Calibration of the controller / 2K- dispenser for exact working	5.9	18
Connection for foot switch and / or external signal	5.2	12
Pressure monitoring at the medium supply with primary pressure	5.10.10	23
Dosing pressure monitor	5.10.9	22
Level monitoring for supply tank / cartridge / tank	8.3	37
Overcurrent monitoring of the connected dispenser to protect against damage due to sticking medium, for example.	5.10.14	27
Visualisation of the operating states via coloured displays	5.4	14

3 Scope of supply

Dosing system **eco-CONTROL EC200 DUO** (delivery as a set with 2K-dispenser)

- 2K dispenser
- Calibration adapter for 2K-dispenser
- Mixer set
- Mains adapter with cable
- SD memory card
- Operating and maintenance instructions
- 2 pressure sensors with installation wrench
- Sticker set for marking components

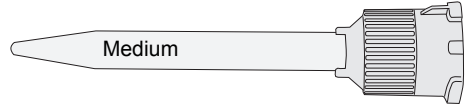
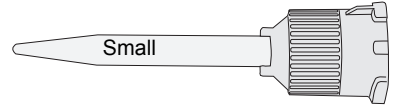

3.1 Mixer set

The mixer set contains three different mixers in the sizes: Small, medium and large. (Fig. in original size)



4 Safety

4.1 Informal safety measures

- The operating and maintenance manual must be kept, together with the operating and maintenance manual of the dispenser(s), at the site where the dosing system is used at all times.
- General and local regulations on health, safety and environmental protection must also be provided and complied with.

4.2 Use of symbols

The following symbols are used in these instructions:

<i>Text in italics</i>	Names of keys/buttons, connectors, chapters, screen displays, proper names and input boxes
•	Listing of the work flow sequence
-	List
1.	Numbered listing of a work flow sequence
1	Legend number in an illustration
	Warning note. Failure to observe these notes may result in injury and damage to the Dosing system.
	Reference to technical information about operation and / or about preventing damage.

4.3 Correct use, warranty

The Dosing system is designed for controlling our dispensers in non explosion-protected environments.

Any

- modifications and additions,
- use of non-genuine spare parts,
- repairs by persons or organisations not authorised by the manufacturer
- use without original sensors for monitoring dosing pressure

that are done without the explicit and written approval of the manufacturer, can lead to the warranty being rendered null and void.

The manufacturer shall have no liability whatsoever for damage resulting from failure to follow the Operating and maintenance instructions.

The chemical resistance of the parts which come into contact with the product (see the commissioning and maintenance manual of the dispenser) must be ensured prior to commissioning.

4.4 Qualifications of the operators and maintenance personnel

The operating organisation is responsible for ensuring that the operators and maintenance personnel are suitably qualified. The Operating and maintenance instructions must have been read and understood. The relevant technical rules and safety regulations must be complied with.

4.5 Organisational measures



The necessary personal protective equipment must be provided by the operating organisation. All safety devices that are fitted must be checked regularly. Safety glasses and overalls must be worn during operation and cleaning to provide protection against any splashes of chemicals.

All of the safety information contained in the respective Operating and maintenance instructions for the dispenser(s) that are connected to the Dosing system must be complied with.

4.6 Preparation for commissioning - visual inspection

The Dosing system must be visually examined each day before the start of work and before all shift changes. If there is any doubt as to the system's readiness for operation, it must be shut down immediately and inspected by a specialist before operation resumes.

4.7 Preventing material damage to the motors of the 2K-dispenser

➔ The 2K-dispenser lead (connector 16, Chapter 5.2, Connections, on page 12) **may only be connected and disconnected when the power supply is isolated.** The electronics in the drive motor could be damaged if this precaution is not taken.

The 2K-dispenser should only be operated with the original pressure sensors connected, which have been adapted to the controller.

4.8 Sources of danger due to Dosing system



Failure to follow the instructions given below can result in damage to the unit and possible severe injury to persons in the vicinity.

- Very high dosing pressures can be produced, depending on the viscosity and the speed of rotation, and this could result in unintended spurting out of the medium. **Check the flow quantity in relation to the dosing needle used (needle cross-section).**
- When it is started up for the first time and after being refilled, air bubbles that are included in the medium could cause an uncontrollable spurting out of the outlet nozzle. **Only start production operation once the Dosing system has been completely bled.**
- Wear suitable protective clothing if chemical, corrosive or dangerous products are being used. **Note and comply with the safety stipulations and the information from the manufacturer.** Ensure sufficient bleeding or extraction of air. Take special safety precautions if working with dangerous media, for example, provide eye flushing facilities if working with corrosive chemicals.

5 Operation



Before commissioning the Dosing system, the safety information in Chapter 4, *Safety*, starting on page 8, must have been read and understood.

5.1 Displays and controls

Item	Function, description	
1+2	Graphic display	
3	Mains switch	
4	NAVI wheel	Select and set variable values and input dialog confirmations.
5	Key (without Fig., below)	For service, software update.
6	Key <i>START</i>	Starts the dosing / function
7	Key <i>STOP</i>	Stops the dosing / function; emergency stop
8	Key <i>PRG / Esc</i>	Selection of programming, quitting an input dialog.
9	Key <i>INFO</i>	Brings further information onto the display, used to quit page 2 in the dosing programs.
10	<i>Return</i>	Confirmation of a selection / value input.

Shortcut keys for dosing programs

11	<i>Time program</i>	on the right, next to the key
12	<i>Start / stop program</i>	is a
13	<i>Quantity program</i>	status LED

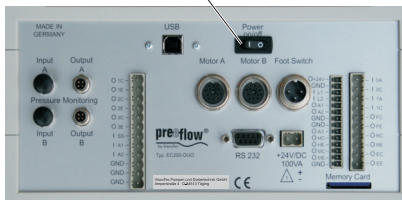
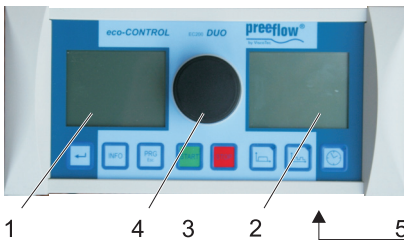

5.2 Connections

Item	Function, description	
14 + 15	System plugs *	
16	Motor A / B	
17	USB	Data transfer with PC, interface
18	Foot switch	Foot switch for hands-free operation
19	System plugs *	
20	RS 232	Data transfer with PC, interface
21	+24 V/DC 100VA *	Mains plug, connection for power supply
22	Memory Card	Card reader for MMC/SD memory card
24	Primary pressure monitoring	Pressure sensor connection for medium components A and B
25	Dosing pressure monitor	Pressure sensor connection for medium components A and B



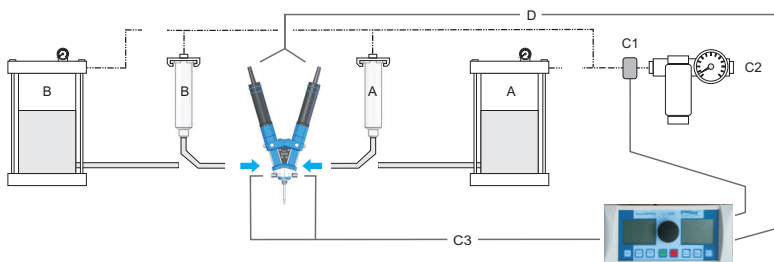
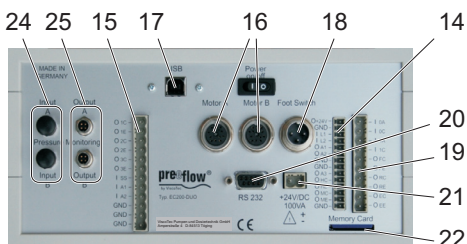







* See section 8.3, page 37 for pin-outs



(The primary pressure does not apply for self-levelling liquids)

- | | | | |
|----|-----------------------------|----|-------------------------|
| A | Product supply A | C2 | Compressed air |
| B | Product supply B | C3 | Dosing pressure monitor |
| C1 | Primary pressure monitoring | D | Power supply dispenser |

5.3 Symbols on the screen

	Designation / function	Description
	Dosing program Quantity	See 5.8.1, Dosing programs, page 17 Quantity program
	Dosing program Start / stop	See 5.8.1, Dosing programs, page 17 Start / stop program
	Dosing program Time	See 5.8.1, Dosing programs, page 17 Time program
	flow rate	Dosing quantity per minute ¹ .
	Sucking back	Preventing dripping of the medium The amount of medium that is "sucked back" into the dispenser in connection with the dosing process.
	Calibrating	Matching the dispenser by determining the effective flow rate.
	Saving	Used to save the last values that had been amended. Only applies if a SD memory card has been inserted.
	Start / stop	Shows the current controlling of the dispenser (high/low). The switch is set to I during dosing.
	Relative quantity, capacity	Dynamic display of the flow rate, for example
	Fault	Plain text messages in the status line give information on the relevant error message. Details can be called up with the Info key.

¹ In ml or g

5.4 Functional and operational schematic

The interaction of the screen displays, the input dialog and the function keys:

The control system has an intuitive input dialog. The selection or the change of a value is offered on the screen to suit the relevant program section. The corresponding area (A) on the screen is then shown as inverse or framed.

The status bar (B) provides plain text messages in accordance with the input dialogs.

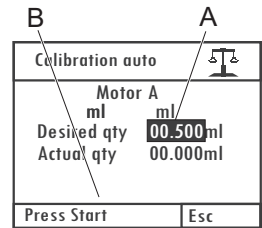

NAVI wheel (See 5.1, Displays and controls, page 11)

Enables rapid selection, input and confirmation of different functions.

The *rotation* of the *NAVI wheel switches* to the next or previous selection, depending on the direction of rotation, or changes a value.

A *press* of the *NAVI wheel confirms* a selection or a change in value that had just been made. (Alternatively, the *Return* key can also be used for confirmation)

The illumination of the *NAVI-wheel* signals the following operating states: Blue = Ready for operation, Green = Dosing in progress, Red = Fault.

Changing a setting value

1. Select the value to be changed by *rotating the NAVI wheel*, the value is shown in inverse.
2. *Press the NAVI wheel*, numbered items can be selected individually.
3. Select a numbered item by *rotating the NAVI wheel*, the numbered item flashes.
4. *Press the NAVI wheel*, the numbered item is shown in inverse.
5. Change the value by *rotating the NAVI wheel* and press the *NAVI wheel* for confirmation, the numbered item flashes again. Another numbered item can be selected.
6. If further numbered items are to be changed, start again from 3., and if not, continue.
7. Press the *PRG* key to confirm the change, the value that has just been set is shown in inverse, if other values can be changed in the input dialog, these can now be reached by *rotating the NAVI wheel*.

Esc

Used to quit an input dialog. In some cases it also assumes other functions. If that is the case, this is shown in plain text in the status line.

5.5 Starting up for the first time

➔ **Caution:** The 2K-dispenser lead (connector 16, Chapter 5.2, Connections on page 12) may only be connected and disconnected when the power supply is isolated. The electronics in the drive motor could be damaged if this precaution is not taken.

- Operate the 2K-dispenser in accordance with the operating manual.
- Ensure that the mains switch has been turned off.
- Funktionsbereitschaft des 2K-Dispensers gemäß der mitgelieferten Inbetriebnahme- und Wartungsanleitung herstellen.
- Connect the plugs of the 2K-dispenser(s).
- Connect the plugs of both 2K-dispenser pressure sensors.
- Connect the power supply to the control system.
- Connect the mains plug of the mains adapter to the electrical mains.
- Turns on the mains switch.

5.5.1 Save the calibration values of the dosing pressure sensors

- Press *PRG*, *system selection menu*, display 2 appears.
- Select *Administration*, display 25 appears.
- Select *Calib. outp. pressure A*, display 51 appears.
- Enter the calibration data supplied with the sensor
- Carry out the same setting with pressure sensor B.

Programs Calibration auto Calibration manuell Service Flush manually A Flush manually B Administration	Display 2
10 47h Fr 18.03.11	

Tol. of input pressure Password protection Calib. Outp. Press. A Calib. Outp. Press. B Analog input Adjust Time	Display 25
10 47h Fr 18.03.11	

Calib. Outp. Press. A	
Cal. factor output signal 094.7 mV	
Insert value	Esc OK

Notice: The Dosing system is only ready for operation when the 2K-dispenser is connected.

Tip: Use the stickers provided (letters A and B), to mark the following components.

- Both motors and dispensers and their plugs
- Pressure sensors and their plugs
- Supply lines for the media used

5.6 Starting up

- Turns on the mains switch.
- Position the new mixer where necessary. The dosing system set is ready for operation.

5.6.1 Important settings

Some important settings must be made to ensure problem-free operation of the 2K-dosing station. The following set-up makes the process easier:

- Mixer used
- Mixing ratio
- Pot life
- or flush time
- Pressure tolerance of the input pressure monitor, where used

5.7 Shutting down

The unit is shut down in reverse order of setting up.

5.8 The dosing programs and their areas of application

General

In order to achieve the most accurate results with the **eco-CONTROL EC200 DUO**, all the main factors for a reproducible dosing operation can be set.

The dosing system must be recalibrated each time the medium is changed. See 5.9, Calibrating page 18.

All the parameters of a dosing program can be saved. When using a memory card, 24 program slots are available for permanent storage.

Without the memory card, the data is stored temporarily on program slot 00. It is kept until the dosing system is switched off.

The following values can be defined, depending on the dosing program used:

Dosing program	Flow quantity	Flow rate	Dosing time	Sucked back quantity	Suck back speed	Pause before Sucking back	Material density
Quantity program	x	x		x	x	x	x
Start / stop program		x		x	x	x	
Time program		x	x	x	x	x	

5.8.1 Dosing programs

Quantity program

Quantity program is used to give out a fixed and defined quantity of medium. Depending on the 2K-dispenser and the medium used, it is possible to set very small amounts per dosing. The dosing time is determined by the volume flow. The dosing operation can be broken off at any time until the set time has expired (*STOP* key).

Start / stop program

The *Start / stop program* is used if the 2K-dispenser is set to convey the medium over an individual period controlled by the operator (or external control). The output quantity can be defined. The dosing quantity is determined by the volume flow.

Time program

The *time program* is used if the dosing is to be done for a set period. This is triggered by the operator (or an external controller). The output quantity can be defined. The dosing operation can be broken off at any time until the set time has expired (*STOP* key). The maximum dosing time that can be set is 99.99 seconds.

5.8.2 Operating modes

Dosing manually

In the three dosing programs the dosing is initiated by pressing the *START* key. The *quantity program* and the *time program* end the dosing by itself once the set values have been reached or at the end of the set dosing time.

In the *Start / stop program* dosing can be ended by pressing the *STOP* key.

Dosing with the foot switch

The dosing system reacts to the foot switch being activated as follows:

Dosing program	Press the foot switch	... and release it again
Quantity program	Quantity program ends	
Start / stop program	Dosing on	Dosing off
Time program	Time program ends	

In the quantity and time programs the dosing can be stopped by pressing the *STOP* key before the specified values have been reached (*EMERGENCY STOP*). A set pause and a return flow are carried out as well.

Dosing by means of an external controller

As in the case of *dosing with the foot switch*, but the triggering and termination of the dosing are done by supplying an electrical signal. See 8.3, Interface description, page 37.

Notice: If a memory card is being used, press the foot switch briefly to load the saved and most recently run program and to display it on the screen. Press the foot switch once again to start the dosing. It behaves in exactly the same way with an external signal.

5.9 Calibrating

Preparation

- Mount the calibration adapter (see 2K-dispenser operating manual).
- Connect to the controller the 2K-dispenser that has been made ready for operation and bled.

Caution: The 2K-dispenser lead (connector 16, Chapter 5.2, Connections on page 12) may only be connected and disconnected when the power supply is isolated. The electronics in the drive motor could be damaged if this precaution is not taken.

- Keep at hand a suitable vessel (calibration vessel) to catch and measure the quantity required for calibration.

5.9.1 Automatic calibration

Notice: During the calibration operation the Dosing system cannot be operated by either the foot switch or an external control signal.

- Press *PRG*, *system selection menu*, display 2 appears.
- Select *Calibration auto*
- Select motor **A** or **B**, menu *Calibration auto*, display 15 appears.

Programs Calibration auto Calibration manuell Service Flush manually A Flush manually B Administration	Display 2
10 47h Fr 18.03.11	

Select whether the calibration is to be done with quantity unit **ml(μl)** or **g(mg)*** and confirm this, the set quantity can be set as desired.

Calibration auto	⚖	Display 15
Motor A	ml	
Desired qty	00.500ml	
Actual qty	00.000ml	
Press Start	Esc	

- Set and confirm the set quantity.
The value preset in the Dosing system is to be regarded as the ideal value.
- Position the calibration vessel under the calibration adapter of the 2K-dispenser.

- Press the **START** key, the calibration starts, the 2K-dispenser is switched on and conveys the quantity specified by the system. This process can be repeated as often as desired. e.g., for comparative measurements.
- The **ACTUAL** quantity that goes into the calibration vessel is determined in the previously set measuring unit. See also 5.10.4, Dosing quantity.
- Input and confirm the **ACTUAL** quantity that has been determined.
- Select the **OK** button and confirm, the next dialog to save the calibration value appears (display 17).

- Accept or discard the suggested program slot, confirm this, and the system has been calibrated.

Calibration auto 	
Save calibration value at prog. no.: <input type="text" value="07"/>	
Save with OK	Esc OK

Display 17

5.9.2 Calibration manual

The *Calibration manual* function provides a simplified option to recalibrate the system without having to run through the entire process in the *Calibration auto* menu.

This can be helpful, for example, after changing the stator, in the event of batch-related product variations, etc., whereby the set dosing value is not to be changed (QA documents, etc.).

➔ **Caution:** Setting the flow rate in the *Calibration manual* menu also changes the dosing results of all the dosing programs by a linear factor.

- Press the **PRG** key, *system selection menu*, display 2 appears.
- Select *Calibration manual*.
- Select motor **A** or **B**, menu *Calibration manual*, display 40 appears.

Programs
Calibration auto
Calibration manuell
Service
Flush manually A
Flush manually B
Administration
10 47h Fr 18.03.11

Display 2

- Confirm the flow rate and set the desired value with the *NAVI wheel*
- Press the *NAVI-wheel* key, *system selection menu*, display 2 appears.

Calibration manual 	
Degree of dosing qty <input type="text" value="100.0"/> %	
Adjustment range 90 ..110%	
Accept with OK	Esc OK

Display 40

5.10 Settings

5.10.1 Mixing ratio

If a dosing program is active, the mixing ratio is shown in the right-hand display and can be changed. The value for dispenser A can be set (1:1 to 5:1).

See also 5.14, *Changing a dosing program*

Mixture	1.0:1.0
Mixer	small
Pot time	00 : 23 : 45
Blank shot	<input type="checkbox"/> endless <input type="checkbox"/>
Flush	<input checked="" type="checkbox"/>
Flushing Time	00 : 23 : 00
Flush A	<input checked="" type="checkbox"/>
Flush B	<input type="checkbox"/>
Program no.	07
	G

Display 26.3

5.10.2 Mixer size

If a dosing program is active, the mixer size is shown in the right-hand display and can be changed.

The three sizes of the supplied mixer set are available for selection: Small, medium and large.

See also 5.14, *Changing a dosing program*

The mixer size is taken into account in the flow quantity in the *Rinse mixer* functions.

Mixture	1.0:1.0
Mixer	small
Pot time	00 : 23 : 45
Blank shot	<input type="checkbox"/> endless <input type="checkbox"/>
Flush	<input checked="" type="checkbox"/>
Flushing Time	00 : 23 : 00
Flush A	<input checked="" type="checkbox"/>
Flush B	<input type="checkbox"/>
Program no.	07
	G

Display 26.3

5.10.3 Setting the pot life, flush the mixer

The pot life is shown in display 26.3. It can be set in every program (Chapter 5.14). It then starts running backwards on every dosing. The remaining time is shown.

It is compulsory to enter the pot life.

Mixture	1.0:1.0
Mixer	small
Pot time	00 : 23 : 45
Blank shot	<input type="checkbox"/> endless <input type="checkbox"/>
Flush	<input checked="" type="checkbox"/>
Flushing Time	00 : 23 : 00
Flush A	<input checked="" type="checkbox"/>
Flush B	<input type="checkbox"/>
Program no.	07
	G

Display 26.3

Once the pot life has expired, dosing takes place (empty shot) in accordance with the set mixer size, filling it with "fresh" medium.

Empty shot = single dosing

Continuous = ongoing in accordance with the pot life.

The *Rinse* function can be activated **after** a pot life has been entered.

The value must be smaller than the pot life. It starts running backwards after the mixer has been filled (while the pot life is running). The remaining time is shown.

Once the flush time has expired, the mixer is rinsed once with the component from the selected dispenser (A or B). This ensures that the mixer is filled with just one medium and protected against sticking. The quantity corresponds to the set mixer size.

5.10.4 Dosing quantity

General on determining the dosing amount.

- ➔ **Notice:** If a value that differs from 100% is set in the *Calibration manual* menu (section 5.9.2), this affects the results of the dosing.

The smallest dosing quantities can be determined most easily via the weight. We recommend setting the material density first.

Dose your required quantity with the *Start / stop program* and weigh it. Now input in the *quantity program* the quantity in **g**.

Setting the dosing amount as a value

1. Press the *Quantity program* shortcut key, display 3 appears.
2. Ensure that the required quantity unit* has been selected in the *Quantity* display area.
3. Set and confirm the dosing amount.

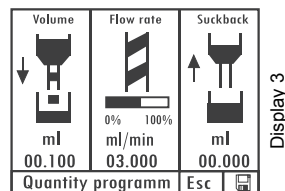

5.10.5 Dosing time

1. Press the *Time program* shortcut key, display 10 appears.
2. Set, confirm and save the dosing time.

The set value remains active until the next change or until the Dosing systems is switched off. Alternatively, a value of its own for the flow rate can be assigned to each dosing program (See 5.14, Changing a dosing program, page 30).

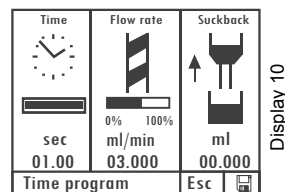

5.10.6 Flow rate

The flow rate in quantity/min can be set in each dosing program. The maximum flow rate that can be set is 6 ml/min, per dispenser (A and B). If a mix ratio of 1:1 is set, 12 ml/min is conveyed.

- Selecting, changing and saving the displayed value.

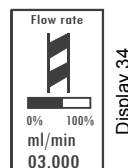

The bar chart shows in what range (%) the flow rate is.

The set value remains active until the next change or until the Dosing systems is switched off. Alternatively, a value of its own for the flow rate can be assigned to each dosing program (See 5.14, Changing a dosing program, page 30).

5.10.7 Sucking back

In order to effectively prevent any dripping of the medium, a value for the sucking back can be set. For safety reasons, the sucking back is restricted to a maximum quantity of 0.02ml.

- Selecting, changing and saving the displayed value.

The sucking back is done after each dosing operation.

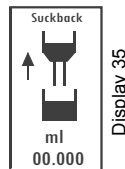

The set value remains active until the next change or until the Dosing systems is switched off. Alternatively, a value of its own for the sucking back can be assigned to each dosing program (See 5.14, Changing a dosing program, page 30).

5.10.8 Dosing time

1. Press the *Time program* shortcut key, display 10 appears.
2. Set, confirm and save the dosing time.

The set value remains active until the next change or until the Dosing systems is switched off.

Alternatively, a value of its own for the flow rate can be assigned to each dosing program (See 5.14, Changing a dosing program, page 30).

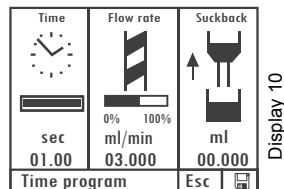

5.10.9 Dosing pressure monitor

➡ The dosing pressure monitor protects the 2K-dispenser. If the mixer were blocked, the pressure inside the dosing pumps could increase to a level where they could be damaged.

In the dosing program currently opened (see also 5.14, Changing a dosing program), the value for the dosing pressure monitor can be entered in level 2 (display 26.1).

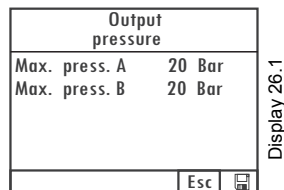

5.10.10 Tolerance value primary pressure monitoring

- Press *PRG*, *system selection menu*, display 2 appears.
- Select *Administration*, display 25 appears.

Programs
Calibration auto
Calibration manuell
Service
Flush manually A
Flush manually B
Administration
10 47h Fr 18.03.11

Display 2

- Select *Inp. pressure tolerance*, display 29 appears.

Tol. of input pressure
Password protection
Calib. Outp. Press. A
Calib. Outp. Press. B
Analog input
Adjust Time
10 47h Fr 18.03.11

Display 25

- In the *pressure tolerance* input dialog, enter the tolerance and confirm with *OK*, display 25 appears.

Tol. of input pressure
Tolerance ± 0.3 Bar
Accept with OK
Esc
OK

Display 29

5.10.11 Password protection

The password protection blocks access to the settings of the controller and all function keys. Dosing is possible via a foot switch (optional) and an external signal (system plug). The most recently selected dosing program is always run and shown on the display.

Setting range for the password: 0000 to 9999

Time of the automatic blocking after the last input: 30 seconds.

Turning on password protection

- Press the *PRG* key, *system selection menu*, display 2 appears.
- Select and confirm *Administration*, the *Administration* menu, display 25 appears.

Programs
Calibration auto
Calibration manuell
Service
Flush manually A
Flush manually B
Administration
10 47h Fr 18.03.11

Display 2

- Select *Password protection*, display 41 appears.

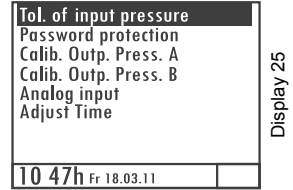

- Press the *Navi wheel*, display *On*, changes to *Off*, *Protection active* appears in the status bar.
- Select and confirm the password (code).
- Set the password by turning* the *Navi wheel*.
- Press the *OK* button and confirm, password protection has been activated.

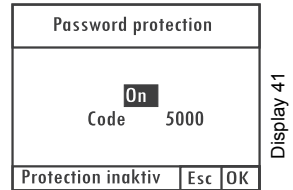

* Dynamic behaviour: The faster it is turned, the quicker the range of numbers changes.

Note: If no further buttons are pressed, the password protection blocks the controller after 30 seconds.

Releasing the controller (if password protection has been activated)

The start screen is shown when it is in the blocked state. Display 42 appears if a button is pressed.

- Select the correct password by turning the *Navi wheel* and confirm it by pressing, then the start screen appears.

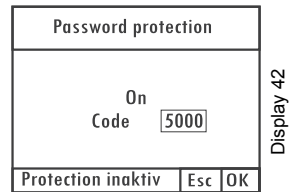

Note: If no further buttons are pressed, the password protection blocks the controller after 30 seconds.

Turning off password protection

Release the controller as described above.

- Press the *PRG* key, *system selection menu*, display 2 appears.
- Select and confirm *Administration*, the *Administration* menu, display 25 appears.

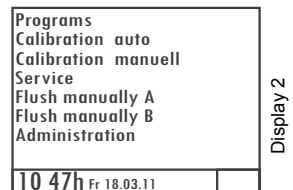

- Select *Password protection*, display 41 appears.

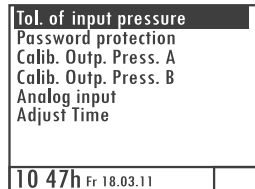

Display 25

- Press the *Navi wheel*, display *Off*, changes to *On*, *Protection inactive* appears in the status bar.
- Press the *OK* button and confirm, password protection has been deactivated.

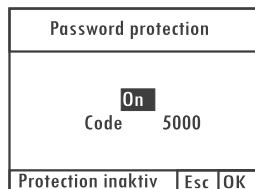

Display 41

5.10.12 Analogue Input

Description: The flow rate (0-6 ml/min) for the connected pump(s) is regulated proportional to the applied analog signal (V or mA).
This function is only effective in the *Start / stop program*.

Technical connection data on the system connector (15)		
Pin	Analog signal	Input resistance / resolution
A1	0-10V	Ri = k 20 kΩ / 10 bit
A2	04-20mA	Ri = 100Ω / 10Bit, maximum input voltage +5V
GND	GND Analog	

Notice: Whatever the setting of the flow rate in the *Start / Stop program*, the maximum flow rate of the pump (0-6 ml/min) must always be assumed. This setting does not affect the return.

Switching the analogue input on / off

- Press the *PRG* key, *system selection menu*, display 2 appears.
- Select and confirm *Administration*, the *Administration menu*, display 25 appears.

Programs	Display 2
Calibration auto	
Calibration manuell	
Service	
Flush manually A	
Flush manually B	
Administration	
10 47h Fr 18.03.11	

- Select *Analogue input*, display 43 appears.
The current setting is shown in the status bar.

Tol. of input pressure	Display 25
Password protection	
Calib. Outp. Press. A	
Calib. Outp. Press. B	
Analogue input	
Adjust Time	
10 47h Fr 18.03.11	

- Select the desired setting and press *Navi wheel*, the status bar displays *Press OK to accept*.
- Select the *OK* button and confirm, the setting is activated.

Analogue input		Display 43
Off	A1 A2	
Analogue activ A2	Esc	OK

Notice: If one of the two analogue inputs is active, this will be indicated in plain text in the display of the *Start / Stop Program* (display 44) instead of the dynamic flow rate display.

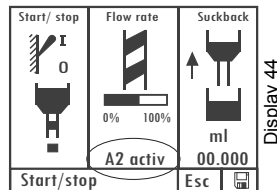

5.10.13 Time and date

- Press *PRG*, *system selection menu*, display 2 appears.
- Select *Administration*, display 25 appears.
- Select *Set the time*, the time and the date can be set by field in the status bar using the *NAVI-wheel*.
- Confirm the setting with *PRG*

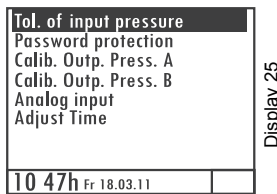
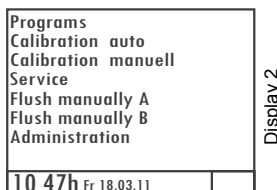

5.10.14 System and error messages

Switching error messages on / off

- Press the *PRG* key, *the start screen*, display 2 appears.
- Press and hold down the *START* key.
- Press the *Quantity program* key,
Config. error messages are displayed (display 33).

Select the desired error message and press the *Enter* key to switch on or off.

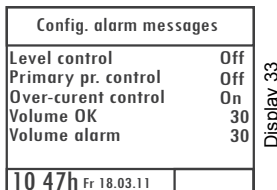
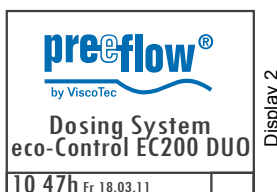

Press the *Esc* key to quit the menu.

The volume is set with the *NAVI wheel* and confirmed with the *Enter* key.

All the values that are set here are saved permanently in the Dosing system.

Notice: The overcurrent monitoring is set permanently to ON.

The primary pressure and level monitoring functions protect the dispenser. This effectively prevents any damage due to running dry if there is too little medium. (Connection for the level signal, see 5.2, Connections, page 12)

Error message memory card

If the memory card is defective or has not been inserted, when the Dosing system is switched on a corresponding message (display 37) is shown for 3 seconds.

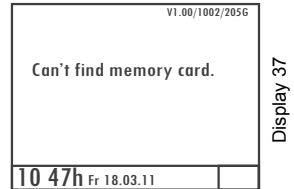

Display 37

5.11 Creating dosing programs

Only possible when using a memory card, a diskette symbol appears in the display at the lower right. If there is no memory card, then only program 00 (volatile memory) is available.

The creation of a dosing program is done as part of the Save function by inputting a dosing program number.

- Select the dosing program (e.g. quantity program).
- Set the values (quantity, flow rate, sucking back).
- Save and input a dosing program number.

Use a memory slot that is still free so that no existing data is overwritten.

All the setting options for this dosing program are now available for editing. Do this as described below under 5.14.

5.12 Selecting the dosing program

Only possible if using a memory card. If there is no memory card, then only program 00 (volatile memory) is available.

- Press *PRG, system selection menu*, display 2 appears.
- Select *Programs*, display 26.5 appears.

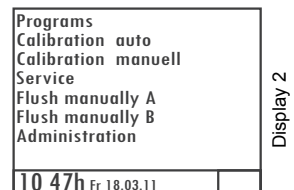

Display 2

- Press *Enter* for longer than 1 second, display 26.4 appears.

Program no.	01 / 1		
Type	Start / stop		
Speed	02.001 g/min		
Suckback	00.000 g		
Speed	03.000 g/min		
Pause	0.00 s		
Calibr.	A: <input type="checkbox"/> B: <input type="checkbox"/>		
10 47h	Fr 18.03.11	Esc	

Display 26.5

- Select the desired dosing program number and confirm, the dosing program is activated and can be used.

Program no.	01 / 1		
Type	Start / stop		
Speed	02.001 g/min		
Suckback	00.000 g		
Speed	03.000 g/min		
Pause	0.00 s		
Calibr.	A: <input type="checkbox"/> B: <input type="checkbox"/>		
10 47h	Fr 18.03.11	Esc	

Display 26.4

5.13 Copying the dosing program

Only possible if using a memory card. If there is no memory card, then only program 00 (volatile memory) is available.

- Select the dosing program to be copied (see 5.12), display 26.5 appears.
- Select the disc symbol at the bottom right, display 27 appears.

Program no.	01 / 1		
Type	Start / stop		
Speed	02.001 g/min		
Suckback	00.000 g		
Speed	03.000 g/min		
Pause	0.00 s		
Calibr.	A: <input type="checkbox"/> B: <input type="checkbox"/>		
10 47h	Fr 18.03.11	Esc	

Display 26.5

- Enter the dosing program number of the new storage space and confirm with OK.

Safe at program no.: 07 ?			
10 47h	Fr 18.03.11	Esc	OK

Display 27

5.14 Changing a dosing program

Only possible if using a memory card. If there is no memory card, then only program 00 (volatile memory) is available.

- Press *PRG*, *system selection menu*, display 2 appears.
- Select *Programs*, display 26.5 appears.

Programs	
Calibration auto	
Calibration manuell	
Service	
Flush manually A	
Flush manually B	
Administration	
10 47h Fr 18.03.11	

Display 2

- Press *Enter* for longer than 1 second, display 26.4 appears.

Program no.	01 / 1
Type	Start / stop
Speed	02.001 g/min
Suckback	00.000 g
Speed	03.000 g/min
Pause	0.00 s
Calibr.	A: <input type="checkbox"/> B: <input type="checkbox"/>
10 47h Fr 18.03.11	Esc

Display 26.5

- Select the desired dosing program number and confirm, the dosing program is activated and can be edited.

Program no.	01 / 1
Type	Start / stop
Speed	02.001 g/min
Suckback	00.000 g
Speed	03.000 g/min
Pause	0.00 s
Calibr.	A: <input type="checkbox"/> B: <input type="checkbox"/>
10 47h Fr 18.03.11	Esc

Display 26.4

Two levels are available for the settings of a program:

Level 1

Program no.	01 / 1
Type	Start / stop
Speed	02.001 g/min
Suckback	00.000 g
Speed	03.000 g/min
Pause	0.00 s
Calibr.	A: <input type="checkbox"/> B: <input type="checkbox"/>
10 47h Fr 18.03.11	Esc

Mixture	1.0:1.0
Mixer	small
Pot time	00 : 23 : 45
Blank shot	<input type="checkbox"/> endless <input type="checkbox"/>
Flush	<input checked="" type="checkbox"/>
Flushing Time	00 : 23 : 00
Flush A	<input checked="" type="checkbox"/>
Flush B	<input type="checkbox"/>
Program no.	07 6

Note: The value in the *Pause* function defines the amount of time between stopping the dosing and starting the sucking back.

Level 2

Program no.	01 / 2
Type	Start / stop
Desired pr.	1.0 / 1.0 Bar
Actual pr.	00.0 / 0.00Bar
Density	1.00/1.00 g/cm ³
Info
User no.
10 47h Fr 18.03.11 Esc 	





Output pressure	
Max. press. A	20 Bar
Max. press. B	20 Bar
Esc 	





The pressure unit *Bar* can be changed over to *psi*.





Select the disk symbol on the bottom right to save.

5.15 Dosing, selected directly without dosing program





- Select the dosing program, this can be done with the shortcut keys for the dosing programs
 - *Quantity program*
 - *Time program*
 - *Start / stop program*.
- The associated main display appears for the relevant dosing program.





 ml 00.100	 ml/min 03.000	 ml 00.000
Quantity programm Esc 		





 sec 01.00	 ml/min 03.000	 ml 00.000
Time program Esc 		

 ml 00.000	 ml/min 03.000	 ml 00.000
Start/stop Esc 		

- Make settings for dosing where necessary.
- If the pot life has not yet been entered, a message appears. Enter the pot life and press *Start*.
- If the mixer has not yet been filled (after every program change) a message appears. Press *Start*, the mixer is filled and the dosing system is ready for operation.
- Press the *Start* key and dosing begins.
- After the first dosing operation the display changes to the associated detail display for the relevant dosing program.

	Program no. 00 Volume 00.100ml Speed 03.000ml/m
	Suckbac 00.000ml Speed 03.000ml/m
	Pause 0.00 s Calibr. A= <input type="checkbox"/> B= <input type="checkbox"/>
Quantity program Esc 	

	Program no. 00 Time 01.00s Speed 03.000ml/m
	Suckbac 00.000ml Speed 03.000ml/m
	Pause 0.00 s Calibr. A= <input type="checkbox"/> B= <input type="checkbox"/>
Time program Esc 	

	Program no. 00 Flow rate Speed 03.000ml/m
	Suckbac 00.000ml Speed 03.000ml/m
	Pause 0.00 s Calibr. A= <input type="checkbox"/> B= <input type="checkbox"/>
Start / stop Esc 	

Detail display

5.16 Dosing, using a dosing program

See 5.12, Selecting the dosing program on page 28.

5.17 Monitoring / displaying dosing pressure

The dosing pressure monitored by the sensors can be displayed as follows when the dosing program is activated.

- Select letter G in the right display (display 26.6) and confirm, the relevant dosing pressure is shown for both pressure sensors in the left display (display 26.7).

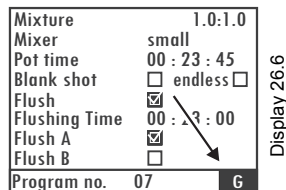

The range of the display corresponds to the settings in the dosing program.

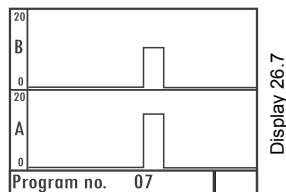

5.18 Manual flush

- Press *PRG*, *system selection menu*, display 2 appears.
- Select *Manual flush A (or B)*, display 52 appears and a single dosing takes place in the selected dispenser. The dosing quantity corresponds to the set mixer size. Display 2 then appears again.

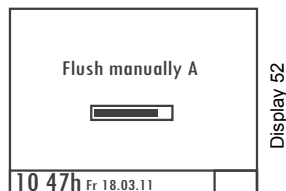
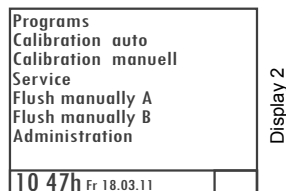

5.19 Bleeding the 2K-dispenser after filling / refilling it and after cleaning

- ➔ **Caution: Do not switch on** the Control system until medium has been delivered to it. Otherwise there is a risk of **damage to the equipment**. Even a **short** test run can cause **irreparable damage to the stator**.

The dispenser must be bled when it is used for the first time and each time after refilling or cleaning. Do this in accordance with the notes given in the operating instructions of the 2K-dispenser.

It is best to use the *start / stop program* with a medium flow rate to control the dispenser.

5.20 Error messages

5.21 Clearing error messages

If an error message is present, a flashing symbol appears in the status bar and an acoustic signal sounds.

(if not switched off, see 5.10.14, System and error messages, page 27)

- Press the *Info* key, the acoustic signal is switched off, and the corresponding error message appears.
 - Overcurrent shutdown! Check the pump and motor
 - Check the minimum fill level
 - Check the compressed air
 - Fill level A (or B) minimum
- Correct the error and clear the error message with *OK*.

- ➔ **Caution:** If the error message *Overcurrent switching* appears, the 2K-dispenser must be cleaned before any further use.

5.22 Error message dosing pressure monitor error

If an error is present in one of the two dosing pressure monitor sensors, an error message appears in the display. The error-code number provided enables us to describe the error exactly. Please tell us the number or replace the relevant sensor.

5.23 Service

5.23.1 Operating information

- Press *PRG*, *system selection menu*, display 2 appears.
- Select *Service* and confirm, display 38 appears.

Programs Calibration auto Calibration manuell Service Flush manually A Flush manually B Administration	Display 2
10 47h Fr 18.03.11	

All the main system and operating times are displayed.
The language for the displays can be set.

ViscoTec EC200 DUO Serial number 7512 Software EC200 2K V1.00 Motor totally 00002h13m System totally 00152h26m Error msg Type of pump eco-PEN450 Language English	Display 38
10 47h Fr 18.03.11	

5.23.2 Formatting the memory card

- Insert the memory card
- Press the *PRG* key, *the start screen*, display 1 appears.
- Press and hold down the *START* key.
- Press the *PRG* key.
- Release both keys again, the memory card is reformatted and all data on the card is deleted. A confirmation message appears on the display: *Chipcard initialized and ok.*

 by ViscoTec Dosing System eco-Control EC200 DUO	Display 1
10 47h Fr 18.03.11	

6

Accessories / spare parts

Item	Part No.	Designation
1	20118	MMC/SD memory card
2	20164	Mains adapter
3	20301	Pressure sensor (primary pressure monitoring)
4	20165	Foot switch cpl. for eco-CONTROL EC200
5	20055	Plug for foot switch
6	20313	"Extender" cable extension 5m cpl.
7	20314	"Extender" cable extension 10m cpl.
8	20326	eco-REMOTE 232 interface ext. Program selection

7 Troubleshooting / Maintenance

Troubleshooting

Fault	Possible cause	Action
Dosing system cannot be operated, no display.	no dispenser connected	Connect dispenser (ensure that the mains plug has been removed beforehand)
	Mains switch turned off	Turn on the mains switch
	Mains adapter has no power or is defective	Check the mains adapter
Dosing program cannot be saved, only program 00 is offered	No MMC/SD memory card inserted, or not formatted	Insert / format the MMC/SD memory card
Error messages		
Overcurrent monitoring	Dispenser components do not run smoothly due to hardened medium or as a result of dry running.	Dismantle and clean the dispenser, replace the stator if necessary. See the operating instructions for the dispenser.
Level of medium critical	Not enough medium in the supply tank	Fill up with the medium. If the error message remains, check the sensor and sensor input, if applicable, brief "emergency operation" without level monitoring.
Motor A (B) not type 450...	Incorrect dispenser connected.	Connect the 2K-dispenser eco-DUO 450
	Drive motor plug not connected	Connect the plug
Error on sensor A (B)	Sensor faulty or not connected	Check the sensor connection, replace.

Maintenance

The Dosing system can be regarded as maintenance free. The ventilation louvres in the mains adapter and housing must be kept clear at all times. Do not use any aggressive solvents or cleaners for cleaning, only a damp cloth. Isolate from the power supply before cleaning.

8 Technical data

8.1 Dosing control

Dimensions (h x w x d)	110 x 240 x 210 mm
Weight	approx. 1.3 kg
Supply	24 V DC, mains adapter supplied
Mains adapter	230 V / 50 / 60 Hz
Performance	max. 50 W depending on the output set
On / off switch	yes
Interface	RS232 / USB
Dosing pressure monitor	0 to 40 bar
External memory	MMC/SD card min 64 MB max. 24 dosing programs
Operating conditions	+10°C to +40°C (Ta.), air pressure 1 bar
Medium temperature	+10°C to +40°C
Storage conditions	dry / dust free -10 to +40°C

8.2 Dispenser

See the commissioning and maintenance manual supplied with the dispenser.

8.3 Interface description

8.3.1 System plugs

Suitable system plugs from the manufacturer Wieland	Article number (Wieland)
Mains switch (2-pin)	25.345.3253.0, RM5.08
System plugs 19	25.345.4053.0, RM5.08
System plugs 15	25.345.4253.0, RM5.08
System plugs 14	25.630.1453.0, RM3.5
Compatible plug terminals: Manufacturers Phoenix-Contact and Weidmüller	

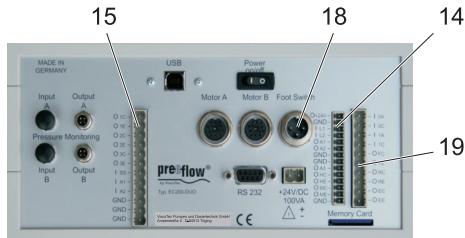

System plugs (14)

Pin	Type	Area	Item
O +24V	Output	+24V/100mA	for supplying the connected sensors
GND	GND	GND	
IL1	Digital input	0/24V	Level sensor 1
IL2			Level sensor 2
OA1	Analogue output	0-5V	Dosing pressure A (no pressure=0V)
OA2			Dosing pressure B (no pressure=0V)
GND	GND	GND	
GND			
OA3	Analogue output	0-5V	Pot life / rinsing time (pot life expired=0V)
OHC	Collector*	max. 24V/10mA	not set
OHE	Emitter*		
OMC	Collector*		
OME	Emitter*		
GND	GND		

* galvanically separated

System plugs (15)

Pin	Type	Area	Item
O1C	Collector*	max. 30V/10mA	Dosing (Dosing running=transistor interconnected)
O1E	Emitter*		
O2C	Collector*		Remote mode (local operating mode or no ecoRemote connected=transistor interconnected)
O2E	Emitter*		
O3C	Collector*		not set
O3E	Emitter*		
ISS	Make contact	0-24V	ext. Start (0V= Stop, 24V=Start)
IA1		0-10V	Analogue input 1 (voltage)
IA2		4-20mA	Analogue input 2 (current)
GND	GND analogue		
GND	GND sensor		
GND			

* galvanically separated

Foot switch (18)

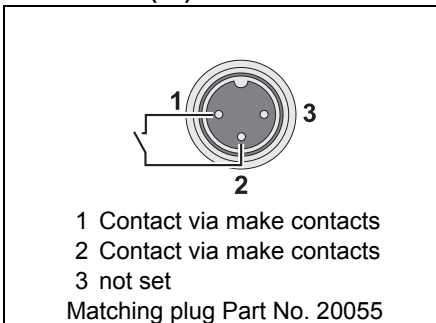

(view of rear of controller EC200)

System plugs (19)

Pin	Type	Area	Item
I0A	galvanically separated	max. 24V/10mA	not set
I0C	galvanically separated		
I1A	galvanically separated	max. 24V/10mA	not set
I1C	galvanically separated		
OFC	Collector*	max. 30V/10mA	Fill level alarm (no alarm=transistor interconnected)
OFE	Emitter*		
ORC	Collector*		Ready for operation (no error=transistor interconnected)
ORE	Emitter*		
OEC	Collector*		Error output
OEE	Emitter*		

* galvanically separated

8.3.2 Logical links of the outputs

Dosing (system plug 15, pins O1C + O1E) The output has H-level during the dosing process, otherwise it has L-level.

Fill level alarm (system plug 19, pins OFC + OFE) The output is activated following successful initialisation (H-level). It switches to L-level if the connected fill level sensor switches to L-level.

Under system and error messages, the fill level monitoring function on page 27 in chapter 5.10.14 can be used to activate or deactivate the monitoring of the sensors.

Ready (system plug 19, pins ORC + ORE) An initialization is carried out after the control system has been switched on. The output is activated when the initialization has been successfully completed (H-level).

Error output (system plug 19, pins OEC + OEE) The output is activated following successful initialisation (H-level). If vacuum, overpressure or overcurrent is registered, the output switches to L-level.

Connections for primary pressure monitoring The sensors for primary pressure monitoring are connected to the connections Input Pressure A and Input Pressure B (24). Entering the tolerance value is described on page 23 in Section 5.10.10.

Inputs

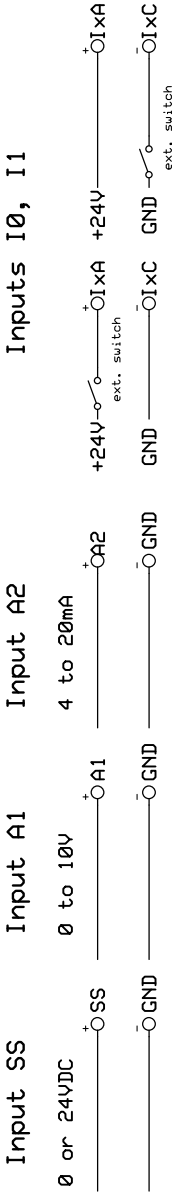

Outputs



External switch + load are examples!

Digital Outputs: max 30VDC / 10mA, NPN-Transistor
 Digital Inputs (Opto-coupler): max 10mA at 24VDC, <1,5V = 0; >12...24V = 1
 integrated Resistor 2K2
 Digital Inputs (without Opto-coupler): <1,5V = 0; >12...24V = 1
 Inputs (I0., I1.): C = Cathode; A = Anode
 Outputs (O1..3; OF, OR, OE): C = Kollektor; E = Emitter

Dosing-Control eco-CONTROL EC200 Art.-Nr.: 20120

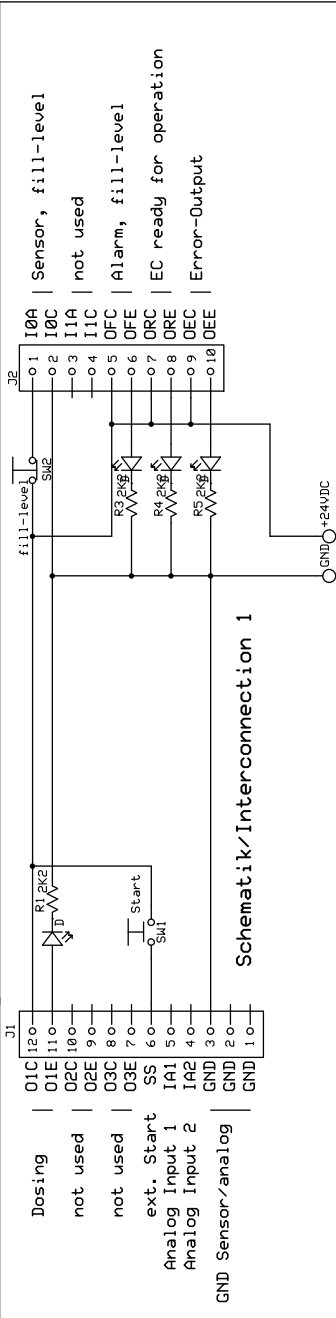

Schematik/Interconnection 1

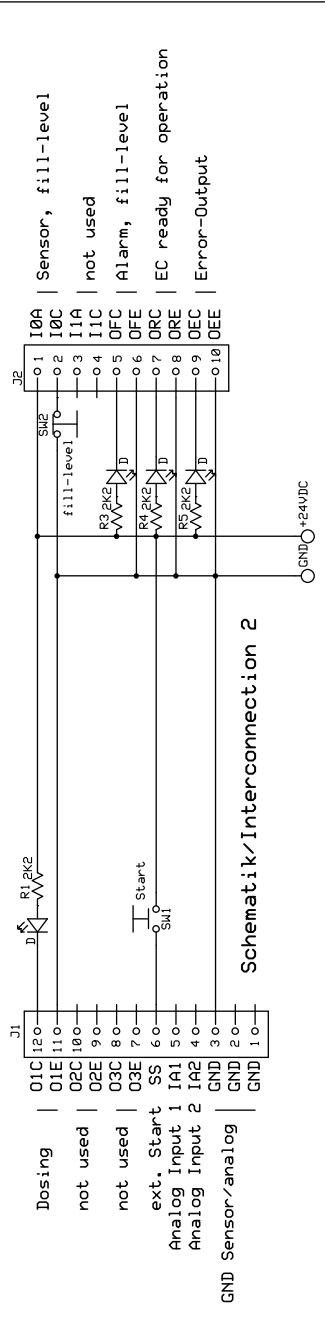

Schematik/Interconnection 2

Digital Outputs: max. 30VDC / 10mA, NPN-Transistor
 Digital Inputs (Opto-coupler): max. 10mA at 24VDC, <1,5V = 0; >12...24V = 1
 integrated Resistor 2K2
 Digital Inputs (without Opto-coupler): <1,5V = 0; >12...24V = 1
 Inputs <I0., I1.>: C = Cathode; A = Anode
 Outputs <O1..3; OF, OR, OE>: C = Kollektor; E = Emitter

9 Disposal



Dispose of the Dosing system in an environmentally safe way. All materials and products left in containers must be treated in accordance with the appropriate recycling requirements.

Electrical components must not be disposed of together with household waste. They must be taken to the collection points provided for this purpose.

2002/96/EU(WEEE)* EU DIRECTIVE concerning used electrical and electronic equipment.

This unit complies with RoHS requirements.

10 EU Manufacturer's Declaration

EU Machine Directive as per Annex II B (2006/42/EG)

EU Low Voltage Directive (2006/95/EG)

EU Directive Electromagnetic Compatibility (2004/108/EG) and changes

Product

Dosing system

eco-CONTROL EC200 DUO

Article number 20120

Manufacturer

ViscoTec Pumpen- und Dosiertechnik GmbH

Amperstrasse 13

D-84513 Töging

We hereby declare that the above-mentioned product conforms to the requirements of the Directives referred to above, and that by virtue of its design and construction, and in the configuration placed on the market by us, it satisfies the applicable requirements.

The following harmonised European standards have been applied:

DIN EN ISO 12100-1 Safety of Machines Part 1 (EN 292-1)

DIN EN ISO 12100-2 Safety of Machines Part 2 (EN 292-2)

DIN EN 809 Pumps and Pump Units for Liquids (Common safety requirements)

Töging, 01.11.2011

Georg Senftl, Geschäftsführer und Bevollmächtigter für die
Zusammenstellung der technischen Unterlagen.
(Anschrift siehe oben)



--	--	--	--



info@preeflow.com
www.preeflow.com